

The economic solution for everyone's food waste issue



Rendisk Transfer Eco

The easy and clean modus to save waste and handling costs.

Rendisk are proud to introduce the “Transfer Eco” food waste management system, which is a cost effective disposal solution to the growing issue that is food waste. It is no longer acceptable to macerate left over food to drain due to the build-up of FOGs (fats, oils and greases) in drain systems and sewers and to tackle this problem, Rendisk are constantly innovating and developing new technology to suit our ever growing client base across all sectors.

Rendisk’s latest product development comes in the form of a pump based food waste system which is perfectly suited to hotels, restaurants, schools, college, universities, care homes, business and industry and several other sector that require food waste management and handling in the most convenient, efficient and cost effective way possible. By choosing the “Transfer Eco” system you choose a future proof solution that has been created with ergonomics, hygiene, ecology and innovation in mind.

When using the “Transfer Eco” system food is deposited into a waste station for environmental disposable, ground and transported through thin 50 mm plastic pipes which are simple and cost effective to install into any new build or existing property. The resulting ground food waste is periodically pumped to a 3,000 or 5,000 Litre PE storage tank, ready for collection by a waste/ garbage truck.

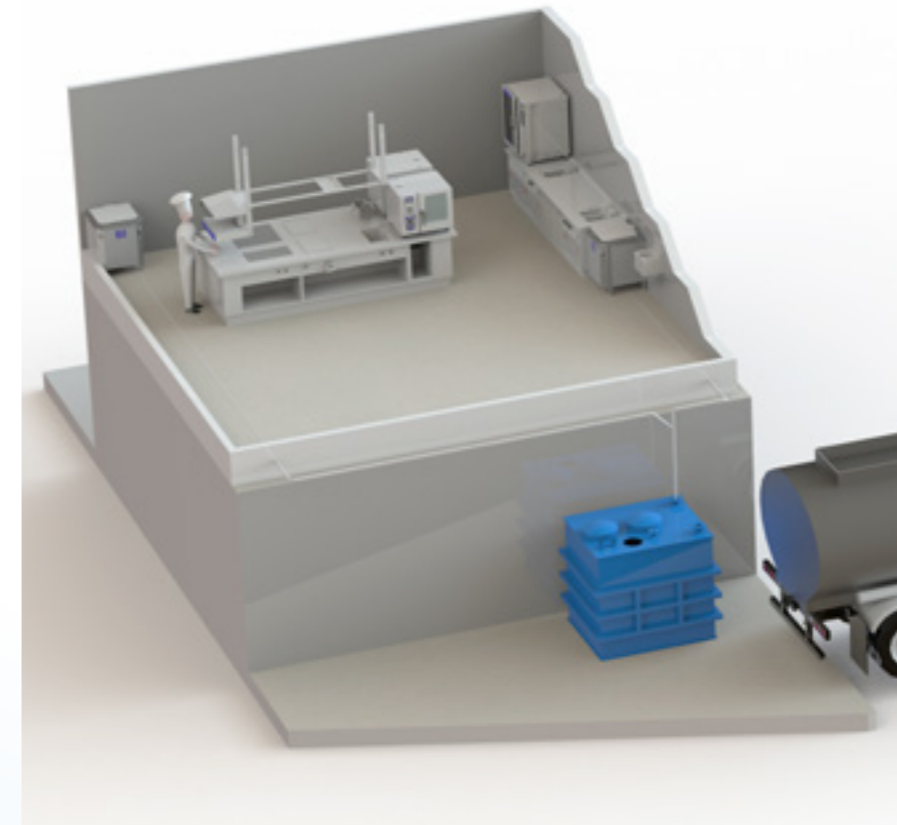

Why choose Transfer Eco as your waste solution?

- Improves kitchen hygiene
- Reduces labour time and costs
- No internal transport of garbage bins and food waste
- Simple and easy operation
- A cost effective solution to waste management

The resulting waste, once transported away from site can then be used as a biogas to organically produce energy due to its calorific content.

“Transfer Eco” is capable of handling all types of food waste thanks to the heavy duty grinder built into all Rendisk waste stations. Bones, seafood shells, coffee and carbohydrates included, no waste separation or double handling is required at all saving time and costs of labour.

System features & details

- Waste stations with heavy duty grinder
- Compact solution, waste station 0.6 m²
- 50 mm PVC piping
- 3,000 or 5,000 Liter PE storage (earth) tank as standard with larger models available on request
- Transportation pump length of up to 45 Meters
- Vertical waste transportation to a maximum height of 2.5 Meters
- System capable of handling up to 450 Kg of waste per hour
- Easy to operate touch panel
- Advanced automatic cleaning cycle

Integrated waste station



Rendisk Transfer Eco*

- A Cover
- B Operator panel
- C Hose for cleaning
- D Main/ safety switch

*Dimensions and specifications of tank available on request.

Technical Data

Waste Station:		Transport pipe:	Outside diameter
Material:	Stainless steel AISI 304		50 mm. 1,5" connection
Capacity:	450 Kg / hour	Electrical:	400 V, 3 ph+ N, 4 KW (3,2 KW motor load) Main circuit breaker C-characteristic
Cycle capacity:	16 Liters/ cycle		
Sound level:	With isolated cover, 69 db.	Storage (earth) Tank:	
Dimensions:	949 X 763 X 745 mm	Holding Capacity:	Standard 3,000 or 5,000 Liters
Hot water:	15 mm for cleaning only (appr. 5 Liters /day)	Outlet connection:	4" or 100 mm
Cold water:	15 mm capacity app. 6 Liters/ cycle	Electrical:	230 V, 1 ph+ N, 0,33 KW

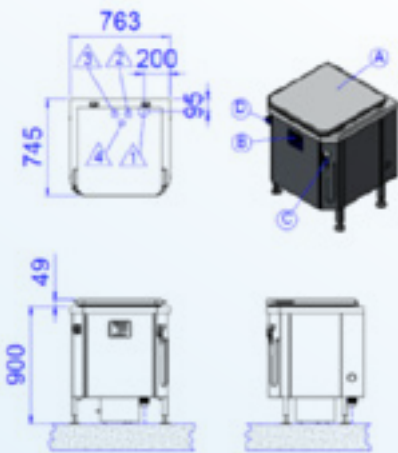

Rendisk Food Waste Solutions

Do process	Do process but follow some simple rules	Do not process
<ul style="list-style-type: none"> Process food leftovers, any kind 	<ul style="list-style-type: none"> Biodegradable and compostable items can be processed in typical 'table quantities' Papers and cardboard should be collected separately, but in small quantities it can be processed 	<ul style="list-style-type: none"> Plastic, glass, tin, metal, textiles, meat rope, film, netting and pollute organic waste must be collected separately

Groundbreaking Solutions in Food Waste Management

Do you want to know how Rendisk can make your kitchen smarter, more efficient and more sustainable? Look for the Rendisk dealer in your country at www.rendisk.com or call +31 (0)800 444 5 444.



RENDISK B.V.
Sporstraat 62
NL-7261 AG Ruurlo
The Netherlands

Paasheuvelweg 29
NL-1105 BG Amsterdam
The Netherlands

CONTACT
T: +31 (0)800 444 5 444
E: info@rendisk.nl
www.rendisk.com